



15370 Barranca Parkway
Irvine, CA 92618-2215
USA

EDGE EVO[®]

Reader Module

EWM-M

INSTALLATION GUIDE

82360-901, Rev B.1

October 2011

© 2009 - 2011 HID Global Corporation. All rights reserved.

Designed for interfacing EDGE EVO Hi-O interface to a traditional Wiegand reader, the Reader Module provides Wiegand and typical reader I/O. Configure the module in two ways, either a Group 1 or Group 2 device. When two readers are present at one access control point, the secure reader side is assigned Group 1. The internal iCLASS reader within an EDGE EVO Standard Reader/Controller is always assigned Group 2.

Specifications

CONDITIONS		VOLTAGE DC (VDC)	CURRENT (Amp)	OPERATING TEMPERATURE	CABLE LENGTH	UL REF NUMBER
Input	DC Input (NSC)	10.8 to 24VDC	0.03Amp	32° - 122°F (0° - 50° C)	Wiegand = 500 ft (152.4 m) - 22 AWG • 0.65mm • 0.33mm ²	MEWMAxNN x = K for Black G for Grey
	DC Input (MAX)	10.8 to 24VDC	0.70Amp			
	Data 1/CLK , Data 0/Data (MAX)	0-5VDC Reference				
Output	Reader PWR Output VDC (MAX)	+9.8 to +12.25VDC	0.32 to 0.60Amp			
	GRN LED, RED LED, Beep and Hold (MAX)	0-5VDC reference	0.005 (sink)			
	External Tamper - (MAX)	+5VDC (NOM)	0.017Amp			

NSC = Normal Standby Condition

Wiring

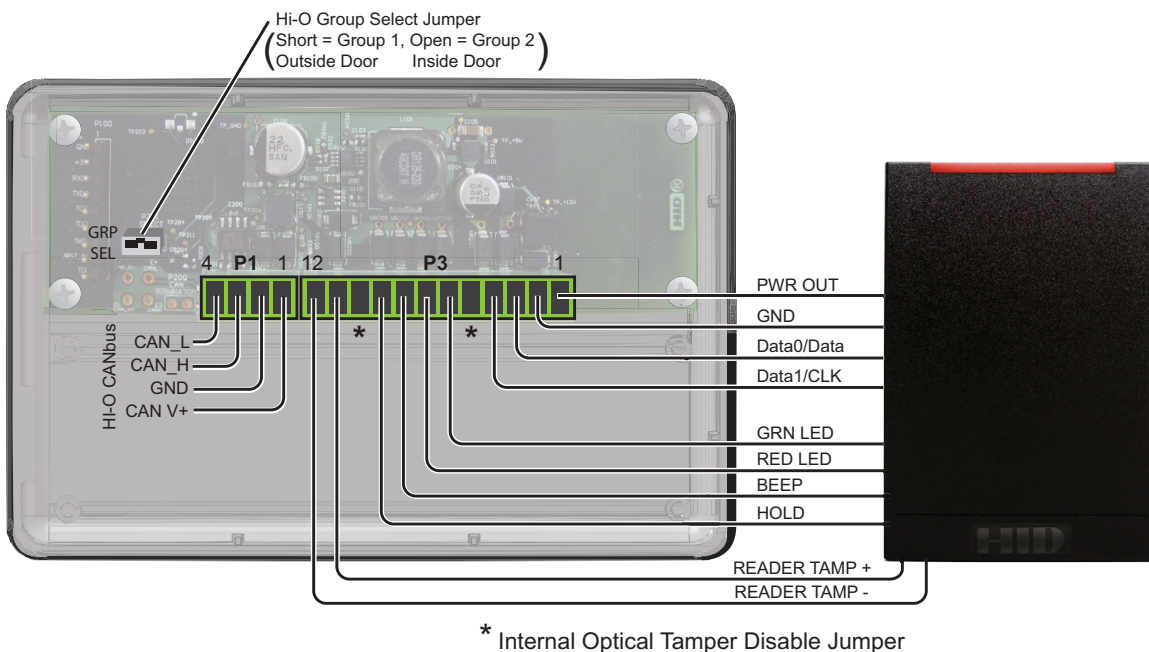

Note: Use Ground (GND) for the drain or tie it to the reader ground if the reader is not powered off of the module (5 VDC reader).

Internal Optical Tamper Disable Jumpers

To disable the internal optical tamper sensor, attach a jumper wire from P3 pin 10 to P3 pin 5.

Note: If desiring an external tamper, wire an unsupervised Normally Closed contact, replacing the pre-installed jumper.

Reader Tamper

The Reader Tamper + and - are implemented allowing a connection for an open collector external tamper from a reader, such as iCLASS.

Note: Connect P3, Pin 2 (GND) from the Reader Interface Board to the same ground as the reader power, if the reader is not powered by the units 12 VDC.

Intentional Blank

Regulatory

UL

Connect only to a Listed Access Control / Burglary power-limited power supply, or Listed Access Control / Burglary PoE (Power-over-Ethernet) adapter. All National and local Electrical codes apply. Install in accordance with NFPA70 (NEC), Local Codes, and authorities having jurisdiction. Indoor use only.

Edge Modules are UL Listed for installation within a protected area.

Mount onto UL Listed Single-Gang electrical box.

All panic and alarm hardware and equipment shall be UL Listed.

All cabling and wire shall be UL Listed or Recognized and suitable for the application.

All splices and connections shall be mechanically secure and bonded electrically.

For operation, testing and maintenance, refer to the EDGE EVO Hi-O Networked Controller & Reader and Standard Networked Controller Installation Guide, 82000-920.

FCC / CANADA RADIO CERTIFICATION

For EDM-M, EIM-M, EWM-M and EDWM-M models: Reader portion (Edge EHR40 and EHRP40 models) certified separately.

These devices comply with part 15 of the FCC rules.

Operation is subject to the following two conditions: (1) This device may not cause harmful interference, and (2) This device must accept any interference received, including interference that may cause undesired operation. Changes or modifications not expressly approved by the party responsible for compliance could void the user's authority to operate the equipment.

Le fonctionnement est soumis aux deux conditions suivantes : (1) Ce dispositif ne peut pas causer de perturbations nuisibles et (2) ce dispositif doit accepter toute perturbation quelconque qu'il reçoit, y compris des

For all models: FCC Class A • Canada Class A • CE Mark – Europe (EU) • C-Tick – Australia and New Zealand • VCCI – Japan

Class A Digital Devices - FCC Compliance Statement: This equipment has been tested and found to comply with the limits for a Class A digital device, pursuant to part 15 of the FCC Rules. These limits are designed to provide reasonable protection against harmful interference when the equipment is operated in a commercial environment. This equipment generates, uses, and can radiate radio frequency energy and, if not installed and used in accordance with the instruction manual, may cause harmful interference to radio communications. Operation of this equipment in a residential area is likely to cause harmful interference in which case the user will be required to correct the interference at his own expense. For regulatory compliance, all connection wires must be bundled together.

CE MARKING

HID Global hereby declares that these modules are in compliance with the essential requirements and other relevant provisions of Directive 1999/5/EC.

The controller portion is in compliance with the essential requirements and other relevant provision of Directive 2004/108/EC.

JAPAN MIC

この装置は認証済みです。

TAIWAN NCC

經型式認證合格之低功率射頻電機，非經許可，公司、商號或使用者均不得擅自變更頻率、加大功率或變更原設計之特性及功能。低功率射頻電機之使用不得影響飛航安全及干擾合法通信；經發現有干擾現象時，應立即停用，並改善至無干擾時方得繼續使用。前項合法通信，指依電信法規定作業之無線電通信。低功率射頻電機須忍受合法通信或工業、科學及醫療用電波輻射性電機設備之干擾。

According to «Administrative Regulations on Low Power Radio Waves Radiated Devices» without permission granted by the NCC, any company, enterprise, or user is not allowed to change frequency, enhance transmitting power or alter original characteristic as well as performance to an approved low power radio-frequency devices. The low power radio-frequency devices shall not influence aircraft security and interfere legal communications; If found, the user shall cease operating immediately until no interference is achieved. The said legal communications means radio communications is operated in compliance with the Telecommunications Act.

The low power radio-frequency devices must be susceptible with the interference from legal communications or ISM radio wave radiated devices.



ACCESS experience.

hidglobal.com

© 2009 - 2011 HID Global Corporation. All rights reserved.

82360-901 Rev B.0

Patent Pending

Check reader label for current regulatory approvals.

HID Global

North America

15370 Barranca Parkway
Irvine, CA 92618
USA
Phone: 800 237 7769
Fax: 949 732 2120

Asia Pacific

19/F 625 King's Road
NorthPoint, Island East
Hong Kong
Phone: 852 3160 9800
Fax: 852 3160 4809

Europe, Middle East & Africa

Phoenix Road
Haverhill, Suffolk CB9 7AE
England
Phone: +44 1440 714 850
Fax: +44 1440 714 840

support.hidglobal.com

HID GLOBAL, HID, the HID logo, EDGE EVO and Hi-O are the trademarks or registered trademarks of HID Global Corporation, or its licensors, in the U.S. and other countries.

An ASSA ABLOY Group brand

ASSA ABLOY